



# Product Specifications

## VC-6000 Monitoring System Monitoring Module – SM-610-A07

User-Defined: up to 12x Vibration inputs, up to 12 x process inputs (*galvanic isolated*), up to 12x Axial position, up to 2x Phase Reference/Speed with 8x Relays

The VC-6000 Monitoring System hardware is used for both stand-alone safety monitoring and condition monitoring using the Compass 6000 monitoring software modules and database. The VC-6000 offers various standard monitoring modules, power supply modules and communication modules. This Product Specification describes the SM-610-A07.

### Applications

The SM-610 series of VC-6000 Monitoring Modules are designed to provide protective monitoring of various types of industrial machines. The SM-610-A07 is specifically designed as a “user-defined” monitoring module, where there are a number of selectable differential inputs and outputs. This is useful for monitoring machines with applications, e.g. in the oil & gas industry.

### General Description

The features and functions common to all SM-610 Monitoring Modules are briefly listed below. Please refer to the VC-6000 Product Specification (BPS 0044) for more information.

- Interfacing with the CI-620 Communication Module
- High speed digital signal processor
- Relay outputs (logic controlled)
- Module OK-relay status indication
- Extensive local LED indication
- Flash memory for storing settings and local logbook
- High speed reaction time
- Alarm limits with programmable hysteresis and response delay time
- Global trip multiply and override
- Extensive self-monitoring functions
- System bus interface to other modules
- Buffered input signal outputs



### Inputs

- Up to 12x vibration input channels– freely configurable with measurements
- 6x binary input channels
- Up to 12x axial position
- Up to 12x process inputs (*Voltage signals over galvanic isolated converters only!*)
- Up to 2x speed inputs, with one dedicated for 1x Master <sup>1</sup> (central) trigger input signal 1x Slave input channel

<sup>1</sup> Providing trigger signals to other SM-610-xxx modules.

Measurements

The measurements available depend on the inputs selected. These can include up to:

- 2x speed/phase reference – rotation direction, zero speed, run up, coast down
- Bandpass – up to 12x single-point and/or up to 6x dual-point pairs with user-defined **ISO** (up to 11x) OR user defined variable (up to 2x) **HP** and **LP filters**
- For bandpass measurements limit monitoring with Alert and Danger limits.

- For axial position and process values higher and lower limit monitoring with Alert and Danger limits is possible.

Outputs

- 8x relays (any combination of Alert and Danger). Selectable for any AC/DC measurement alarm limits. Relay logic operators AND, OR, NOT, and ( ) can be used in a user-defined voting logic with any combination of measurement alarm limits

Input Channel Configuration Combinations

<sup>1</sup> A dual-point band-pass measurement can alternatively be set up as two single-point measurements and vice versa.

No.	Channels/Measurements							Outputs	
	Variable Band-pass		ISO Filter		Axial Position / Process signals over galvanic Isolators	Speed/Phase Reference	Vector meas.	Binary-Inputs	Relays
Dual-Point Vibr. <sup>1</sup>	Single-Point Vibr. <sup>1</sup>	Dual-Point Vibr. <sup>1</sup>	Single-Point Vibr. <sup>1</sup>						
1	-	-	5	11	1	-	-	6	8
2	-	-	5	11	-	1	4	6	8
3	-	-	5	10	2	-	-	6	8
4	-	-	5	10	1	1	4	6	8
5	-	-	5	10	-	2	3	6	8
6	-	-	4	9	3	-	-	6	8
7			4	9	2	1	4	6	8
8			4	9	1	2	4	6	8
9			4	8	4	-	-	6	8
10			4	8	3	1	4	6	8
11			4	8	2	2	4	6	8
12			3	7	5	-	-	6	8
13			3	7	4	1	4	6	8
14			3	7	3	2	4	6	8
15			3	3	6	-	-	6	8
16			3	3	5	1	4	6	8
17			3	3	4	2	4	6	8
18			2	5	7	-	-	6	8
19			2	5	6	1	4	6	8
20			2	5	5	2	4	6	8
21			2	4	8	-	-	6	8
22			2	4	7	1	4	6	8
23			2	4	6	2	4	6	8
24			1	3	9	-	-	6	8
25			1	3	8	1	3	6	8
26			1	3	7	2	3	6	8
27			1	2	10	-	-	6	8
28			1	2	9	1	2	6	8
29			1	2	8	2	2	6	8
30			-	1	11	-	-	6	8
31			-	1	10	1	1	6	8
32			-	1	9	2	1	6	8

Product Specifications - VC-6000 Monitoring Module – SM-610-A07

No.	Channels/Measurements							Outputs	
	Variable Band-pass		ISO Filter		Axial Position / Process signals over galvanic Isolators	Speed/Phase Reference	Vector meas.	Binary- Inputs	Relays
Dual- Point Vibr. <sup>1</sup>	Single- Point Vibr. <sup>1</sup>	Dual- Point Vibr. <sup>1</sup>	Single- Point Vibr. <sup>1</sup>						
33			-	-	12	-	-	6	8
34			-	-	11	1	-	6	8
35			-	-	10	2	-	6	8
36		1	5	11	-	-	-	6	8
37		1	5	10	1	-	-	6	8
38		1	5	10	-	1	-	6	8
39		1	4	9	2	-	-	6	8
40		1	4	9	1	1	2	6	8
41		1	4	9	-	2	2	6	8
42		1	4	9	-	1	3	6	8
43		1	4	8	3	-	-	6	8
44		1	4	8	2	-	4	6	8
45		1	4	8	1	2	1	6	8
46		1	4	8	-	2	2	6	8
47		1	3	7	4	-	-	6	8
48		1	3	7	3	1	4	6	8
49		1	3	7	2	2	2	6	8
50		1	3	7	1	2	4	6	8
51		1	3	6	5	-	-	6	8
52		1	3	6	4	1	4	6	8
53		1	3	6	3	2	4	6	8
54		1	2	5	6	-	-	6	8
55		1	2	5	5	1	4	6	8
56		1	2	5	4	2	4	6	8
57		1	2	4	7	-	-	6	8
58		1	2	4	6	1	4	6	8
59		1	2	4	5	2	4	6	8
60		1	2	3	8	-	-	6	8
61		1	2	3	7	1	4	6	8
62		1	2	3	6	2	4	6	8
63		1	1	2	9	-	-	6	8
64		1	1	2	8	1	3	6	8
65		1	1	2	7	2	3	6	8
66		1	-	1	10	-	-	6	8
67		1	-	1	9	1	2	6	8
68		1	-	1	8	2	2	6	8
69		1	-	-	11	-	-	6	8
70		1	-	-	10	1	1	6	8
71		1	-	-	9	2	1	6	8
72	1	2	4	9	1	-	-	6	8
73	1	2	4	8	2	-	-	6	8
74	1	2	4	8	-	1	-	6	8
75	1	2	3	7	3	-	-	6	8
76	1	2	3	7	2	1	-	6	8
77	1	2	3	7	1	1	1	6	8
78	1	2	3	7	-	1	2	6	8
79	1	2	3	6	4	-	-	6	8
80	1	2	3	6	3	1	1	6	8
81	1	2	3	6	2	1	3	6	8
82	1	2	3	6	1	2	0	6	8
83	1	2	3	6	1	1	4	6	8
84	1	2	3	6	-	2	1	6	8
85	1	2	2	5	-	-	-	6	8

No.	Channels/Measurements								Outputs
	Variable Band-pass		ISO Filter		Axial Position / Process signals over galvanic Isolators	Speed/Phase Reference	Vector meas.	Binary- Inputs	Relays
Dual- Point Vibr. <sup>1</sup>	Single- Point Vibr. <sup>1</sup>	Dual- Point Vibr. <sup>1</sup>	Single- Point Vibr. <sup>1</sup>						
86	1	2	2	5	4	1	3	6	8
87	1	2	2	5	3	2	-	6	8
88	1	2	2	5	3	1	4	6	8
89	1	2	2	5	2	2	1	6	8
90	1	2	2	5	1	2	3	6	8
91	1	2	2	5	-	2	4	6	8
92	1	2	2	4	6	-	-	6	8
93	1	2	2	4	5	1	4	6	8
94	1	2	2	4	4	2	2	6	8
95	1	2	2	4	3	2	3	6	8
96	1	2	2	4	2	2	4	6	8
97	1	2	2	3	7	0	0	6	8
98	1	2	2	3	6	1	4	6	8
99	1	2	2	3	5	2	3	6	8
100	1	2	3	3	4	2	4	6	8
101	1	2	1	2	8	-	-	6	8
102	1	2	1	2	7	1	4	6	8
103	1	2	1	2	6	2	4	6	8
104	1	2	-	1	9	-	-	6	8
105	1	2	-	1	8	1	3	6	8
106	1	2	-	1	7	2	3	6	8
107	1	2	-	-	10	-	-	6	8
108	1	2	-	-	9	1	2	6	8
109	1	2	-	-	8	2	2	6	8

<sup>1</sup> A dual-point band-pass measurement can alternatively be set up as two single-point measurements and vice versa.

Table 1: Input channel combinations

Signal Flow Diagrams

User Definable Measurement Channel Inputs (maximum subject to overall input allocation).

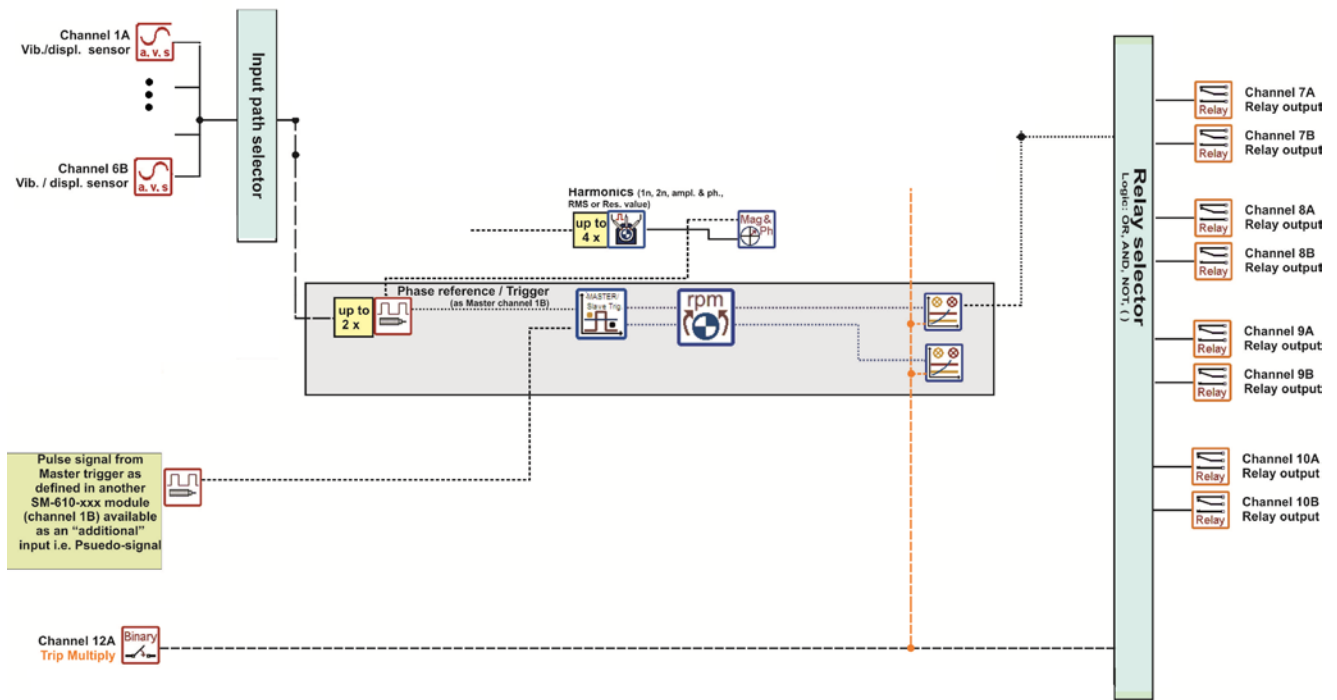

Figure 1: Speed reference sensor input (selectable in 2 input channels), additionally a SLAVE Trigger input is available. The Trip Multiply functionality is controlled over Binary input channel 12A. If not needed for Trip Multiply it could be used in the Voting relay logic.

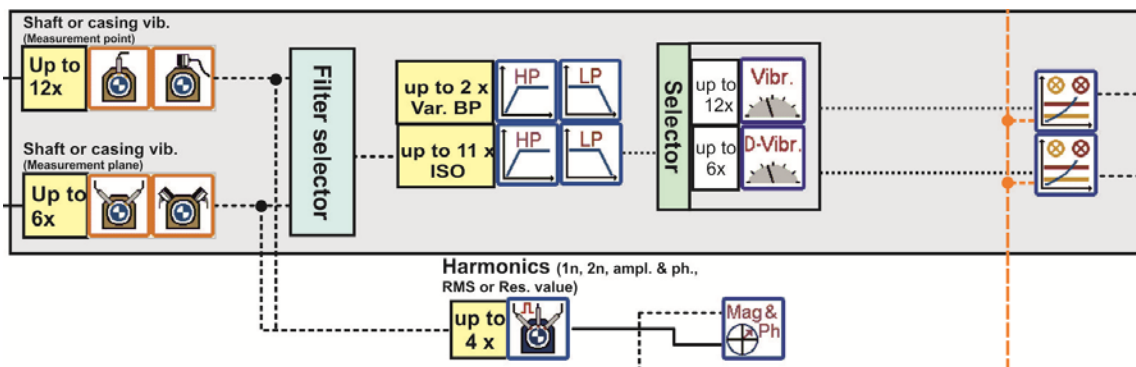

Figure 2: 12 vibration input channels – freely assignable to any input channel with additionally up to 4x Harmonic measurements

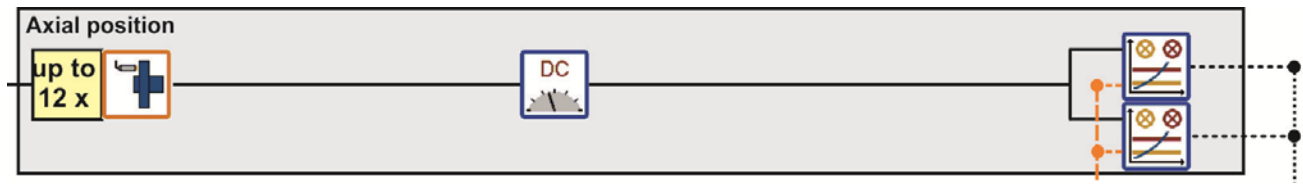

Figure 3: 12 axial position input channels – freely assignable to any input channel

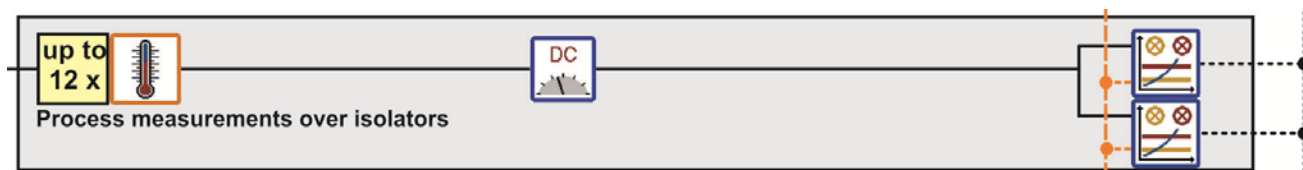

Figure 4: 12 process channel inputs freely assignable to any input channel – **Voltage input signals over a galvanic isolated converter!**

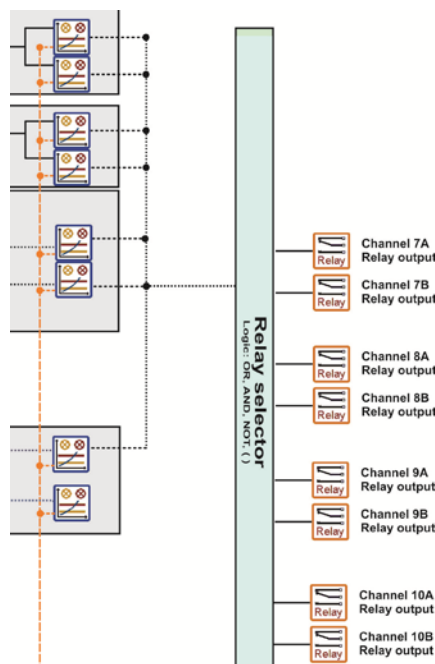

Figure 5: 8 output relays can be assigned with a free voting logic to any limit and binary input within the SM-610-A07 module

## Technical Specifications

The specifications given below are specific for the SM-610-A07 Monitoring Module. See the VC-6000 Product Specifications for features and functions common to all SM-610 Monitoring modules.

### AC/DC Vibration Sensor Inputs

Input voltage range ..... -21.5V to -1V

#### Input frequency range:

Accelerometer/velocity sensor..... 1Hz to 20kHz  
 Displacement sensor ..... DC to 20kHz

#### Input impedance:

Accelerometer.....>800kΩ  
 Velocity sensor ..... 50kΩ  
 Displacement sensor .....>800kΩ

#### Gain:

Accelerometer sensor:  
 No integration ..... 1 to 80  
 Analogue integration..... 1 to 80  
 Velocity sensor ..... 1 to 80  
 Displacement<sup>1</sup> sensor ..... 1

#### Sensitivity:

Accelerometer.....adjustable (e.g. 100mV/g)  
 Velocity sensor ..... adjustable (e.g. 100mV/mm/s)  
 Displacement sensor .....adjustable (e.g. 8mV/μm)

#### Common mode rejection:

DC to 30kHz ..... typically 90dB  
 30kHz to 100kHz ..... typically 85dB

#### Maximum accelerometer input signal (100mV/g):

No integration ..... 1.25g to 80g peak  
 Analogue integration....12.5mm/s to 150mm/s peak

#### Sensor power:

Sensor supply ..... -24VDC ±2%  
 Maximum current.....30mA

### Process Inputs

Input voltage range .....-1V ... -20V

*over galvanic isolated converter!*

Input frequency range ..... DC to 20kHz

Sensitivity ..... adjustable

Sensor power..... external

### Speed/Phase Reference Sensor Inputs

Input voltage range ..... -21.5V to -1V

Input frequency range ..... DC to 20kHz

Input impedance .....>800kΩ

Gain ..... 1

#### Common mode rejection:

DC to 10kHz ..... typically 90dB  
 10kHz to 100kHz ..... typically 85dB

#### Sensor power:

Sensor supply ..... -24VDC ±2%  
 Maximum current.....30mA

### Binary Inputs

Input impedance .....3.3kΩ

Response time ..... < 5ms

Minimum current load (non-active signals) .....5mA

Maximum contact voltage .....±50V

#### Signal status LOW:

Nominal input voltage ..... 0V

Input voltage range ..... -50V to 6.6V

Maximum input current .....2mA

#### Signal status HIGH:

Nominal input voltage .....24V

Input voltage range ..... 16.5V to 50V

Minimum input current .....5mA

### Buffered Outputs

Minimum load impedance ..... 10kΩ / 1nF

Output gain ..... 1 (±2%)

Inherent noise (1Hz to 50kHz)..... typically 10mV RMS

Output impedance ..... <100Ω

Frequency range ..... DC to 50kHz (phase distortion < 5°)

Output offset ..... < 15mV

### Relay Outputs

Nominal working voltage..... 24V

Maximum current ..... 100mA

## Measurements

Meas. Name	Frequency Range	Measuring Time	Detection	Alarm Limits	Measuring Range	Units <sup>1</sup>	Accuracy (25°C, 80Hz, 0-Peak)
Bandpass (ISO 10816)	HP: 1Hz to 10Hz (-1dB) LP: 1kHz (-1dB) 18dB/Octave (ISO 2954)	Adjustable 100ms to 100s in steps of 100ms	RMS, Peak, Peak-Peak	1x Alert, 1x Danger	80g	g	±(0.08g + 0.5% of measured value)
					150mm/s <sup>2</sup>	mm/s	±(0.6mm/s + 0.8% of measured value)
					100mm/s	mm/s	±(0.1mm/s + 0.5% of measured value)
Bandpass (ISO 7919)	HP: 1Hz to 10Hz (-1dB) LP: 1kHz (-1dB) 18dB/Octave (ISO 2954)	Adjustable 100ms to 100s in steps of 100ms	RMS, Peak, Peak-Peak	1x Alert, 1x Danger	2000µm	µm	±(10.0µm + 0.5% of measured value)
S <sub>max</sub>	HP: 1Hz to 16kHz (-1dB) LP: 1.25Hz to 20kHz (-1dB) 18dB/Octave (ISO 2954)	Adjustable 100ms to 100s in steps of 100ms	Peak	1x Alert, 1x Danger	2000µm	µm	±(10.0µm + 0.5% of measured value)
X-Y <sub>max</sub>	HP: 1Hz to 16kHz (-1dB) LP: 1.25Hz to 20kHz (-1dB) 18dB/Octave (ISO 2954)	Adjustable 100ms to 100s in steps of 100ms	RMS, Peak, Peak-Peak	1x Alert, 1x Danger	80g	g	±(0.08g + 0.5% of measured value)
					150mm/s <sup>2</sup>	mm/s	±(0.6mm/s + 0.8% of measured value)
					100mm/s	mm/s	±(0.1mm/s + 0.5% of measured value)
Variable bandpass	HP: 1Hz to 16kHz (-1dB) LP: 1.25Hz to 20kHz (-1dB) 18dB/Octave (ISO 2954)	Adjustable 100ms to 100s in steps of 100ms	RMS, Peak, Peak-Peak	1x Alert, 1x Danger	2000µm	µm	±(10.0µm + 0.5% of measured value)
					80g	g	±(0.08g + 0.5% of measured value)
					150mm/s <sup>2</sup>	mm/s	±(0.6mm/s + 0.8% of measured value)
DC (axial)	-	Adjustable 10ms to 100s	-	2x Alert, 2x Danger	100mm/s	mm/s	±(0.1mm/s + 0.5% of measured value)
					2000µm	µm	±(10.0µm + 0.5% of measured value)
					80g	g	±(0.08g + 0.5% of measured value)
DC (gap voltage) <sup>3</sup>	-	-	-	-	22.0 V	V	±(30.0mV + 0.5% of measured value)
DC (process signals)	-	Adjustable 10ms to 100s	-	2x Alert, 2x Danger	-1V ...-20V <i>galvanic isolated!</i>	V	±(30.0mV + 0.5% of measured value)
Vector (1n, 2n, Xn Yn, RMS and Residual value)	Fundamental: 0.33Hz-1kHz Bandwidth: 22%, 11%, 6%, 3% 44% (fixed for residual value) Upper freq.:5kHz	Computed from bandwidth	RMS, Peak, Peak-Peak	1x Alert, 1x Danger (1n & 2n)	1n, 2n, Xn and Yn (magnitude and phase), RMS or residual value	g, mm/s, µm <sup>4</sup>	Magnitude: <1% + 0.2% of measured value
							Phase 10 to 200Hz: <2°
							Phase to 500Hz: <4° Phase to 1000Hz: < 10°
RPM	Signal slope: +/- Trigger level (manual or automatic): -1.0V to - 21.5V; adjustable in steps of 0.1V Hysteresis: 0 to 25V; adjustable in steps of 0.1V	Adjustable 10ms to 100s	RPM	1x Alert, 1x Danger	0.06 to > 1500000 RPM RPM multiplier and divider adjustable from 1 to 99999	RPM	Speed >10000rpm: ±0.01% of measured value Speed 100 to 10000 rpm: ±1 rpm Speed < 100 rpm: ±0.1 rpm (one pulse per revolution)

<sup>1</sup> Metric and imperial units can be used; Metric units are shown only as an example.

<sup>2</sup> One analogue integration is possible. An additional integration can be done with ISO filter settings, but this will result in loss of accuracy.

<sup>3</sup> Only available for displacement sensor measurements e.g. vibration displacement, axial etc.

**Please note:** For Condition Monitoring all kinds of adapted measurement are possible.

*Brüel & Kjær Vibro reserves the right to change specifications without notice*

**Brüel & Kjær Vibro A/S**  
2850 Nærum – Denmark  
Tel.: +45 7741 2500  
Fax: +45 4580 2937  
E-mail: info@bkvibro.com

**Brüel & Kjær Vibro GmbH**  
64293 Darmstadt – Germany  
Tel.: +49 (0) 6151 428 1100  
Fax: +49 (0) 6151 428 1200  
E-mail: info@bkvibro.de