



Product Specifications

VC-6000 Monitoring System

Monitoring Module – SM-610-153

4x Vibration (Vector Measurements), 2x Axial Displacement, 1x Speed Channel,
7x DC Outputs, 8x Relays

The VC-6000 Monitoring System hardware is used for both stand-alone safety monitoring and condition monitoring using the Compass 6000 monitoring software modules and database. The VC-6000 offers various standard monitoring modules, power supply modules and communication modules. This Product Specification describes the SM-610-153.

Applications

The SM-610 series of VC-6000 Monitoring Modules are designed to provide protective monitoring of various types of industrial machines. The SM-610-153 is specifically designed for monitoring AC/DC vibration of a machine. This includes monitoring vector measurements to alarm limits and axial displacement measurements.

General Description

The features and functions common to all SM-610 Monitoring Modules are briefly listed below. Please refer to the VC-6000 Product Specifications (BPS 0044) for more information.

- Interfacing with the CI-6xx Communication Modules
- High speed digital signal processor
- Relay outputs (logic controlled)
- OK-relay status indication
- Extensive local LED indication
- Flash memory for storing settings and local logbook
- High speed reaction time - 10ms
- Alarm limits with programmable hysteresis and response delay time
- Global trip multiply and override
- Extensive self-monitoring functions
- System bus interface to other modules
- Buffered vibration outputs



Inputs

- 4x vibration signals – up to 2x dual-point measurements
- 2x axial displacement signals
- 1x speed/phase reference signal

Outputs

- 7x analogue DC outputs
- 8x relays (4x Danger, 4x Alert):
 - 2x speed
 - 4x vibration – 2-out-of-4 voting logic
 - 2x axial

Measurements

- 4x bandpass (ISO 7919 or ISO 10816)
- Up to 2x S_{max} or Max(X-Y)
- Vector
- 2x DC (axial)
- 1x RPM

Input Channel Configuration Combinations

Monitoring Module – SM-610-153 4x Vibration (Vector Measurements), 2x Axial Displacement, 1x Speed Channel, 7x DC Outputs, 8x Relays																					
No. of Inputs ¹	Channel Types																	Additional Measurements		Relay's	
	Dual-point Vibr. ² (ISO) ⁹	DC-out	Single-point Vibr (ISO)	DC-out	Axial Pos.	DC-out	Speed	DC-out	Rod Drop	DC-out	Rel. Exp.	DC-out	Eccentricity	DC-out	DC Input (Process, Absolute Exp)	DC-out	Bin. in	Vector ³	BP		Tracking BP
7	(4)	-	4	4	2	2	1	1										4			Axial: 2x 1oo2 2x 1oo1 for RPM Radial: 2x 2oo4 for each Two-point (A BP, A X1, B BP, B X1)
7	(2)	-	4	4	2	2	1	1										4			
7	-	-	4	4	2	2	1	1										4			
¹ The number of input signals is the sum total of the channels shown in yellow. ² Dual-point measurements can alternatively be set up as single-point measurement. There is a limitation with regard to the number of DC-out's (e.g. 6 single-point vibration have only 4 DC-out available – this is not important for condition monitoring applications, however, for safety monitoring requiring DC-out for the primary measurements it is important to know). ³ The vector values (1n, 2n, Jn, Kn magnitude and phase, residual values, and overall RMS) are for condition monitoring purposes only.																					

¹ The number of input signals is the sum total of the channels shown in yellow.

² Dual-point measurements can alternatively be set up as single-point measurement.

³ Only 1n magnitude is monitored to alarm limits, the other vector values (1n phase, 2n, Jn, Kn magnitude and phase, residual values, and overall RMS) are for condition monitoring purposes only.

Signal Flow Diagrams

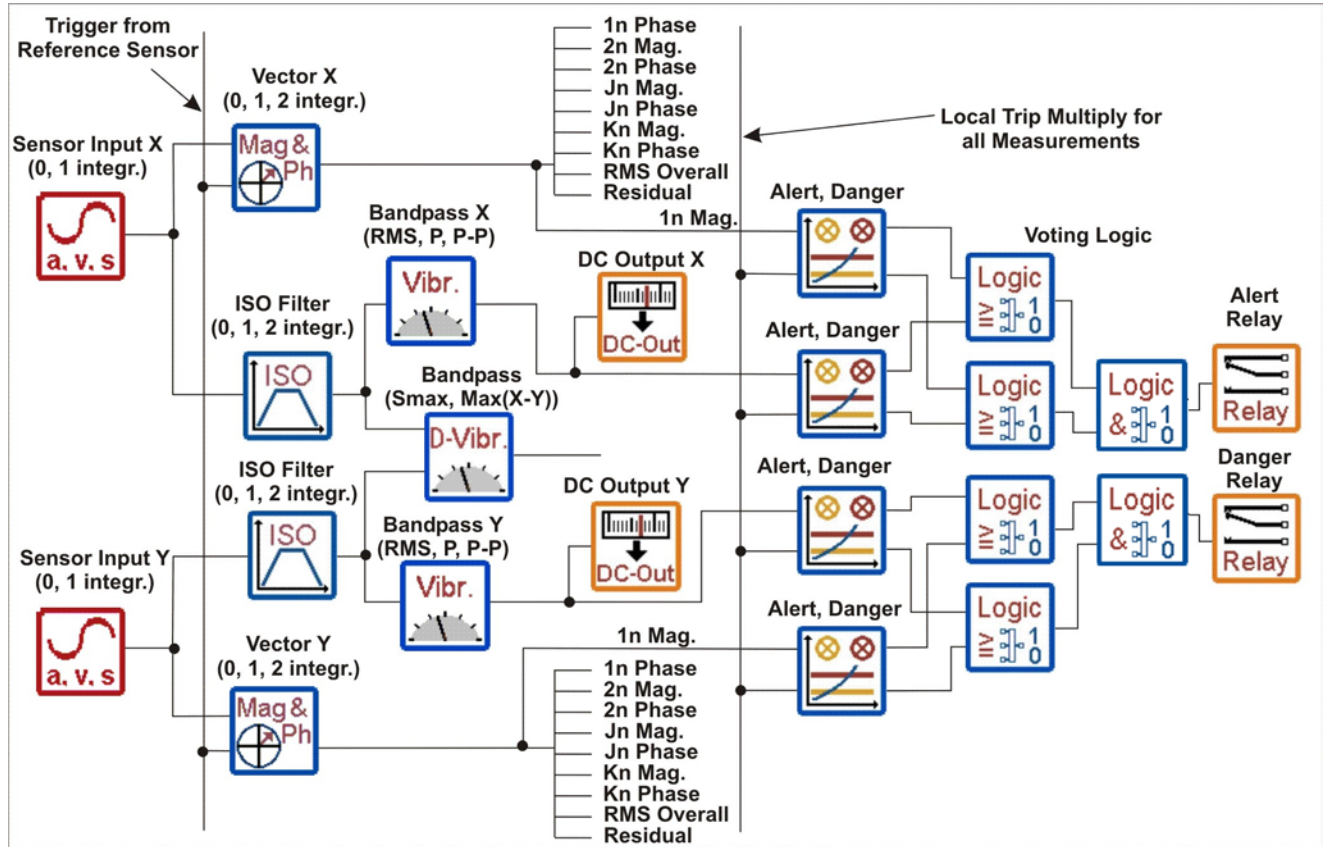

Figure 1. Dual-point AC/DC vibration input (up to 4 channels – 2 pairs). The Smax/Max(X-Y) measurement is for condition monitoring purposes only. Two single-point AC/DC vibration inputs can alternatively be set up from a dual-point input. Only 1n magnitude is monitored to alarm limits, the other vector values (1n phase, 2n, Jn, Kn phase and magnitude, residual values, and overall RMS) are for condition monitoring purposes only. Separate 2-out-of-4 voting logic is used for bandpass and 1st order magnitude measurements for Alert and Danger alarm control.

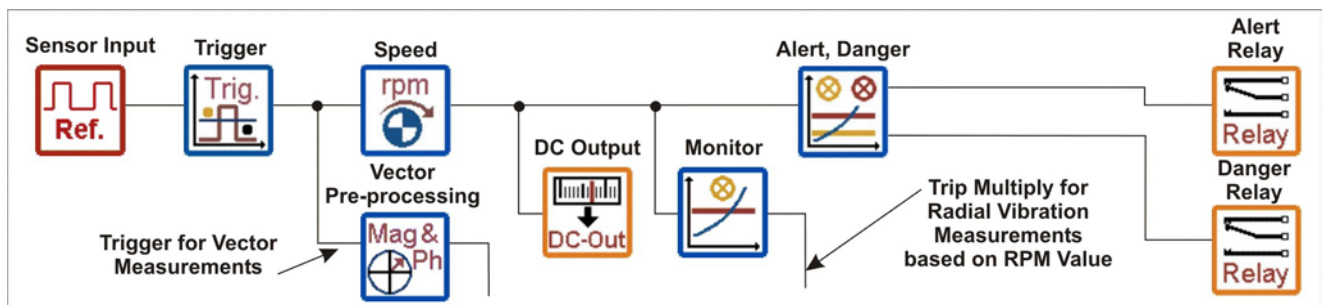

Figure 3. Speed/phase reference sensor input (1 channel).

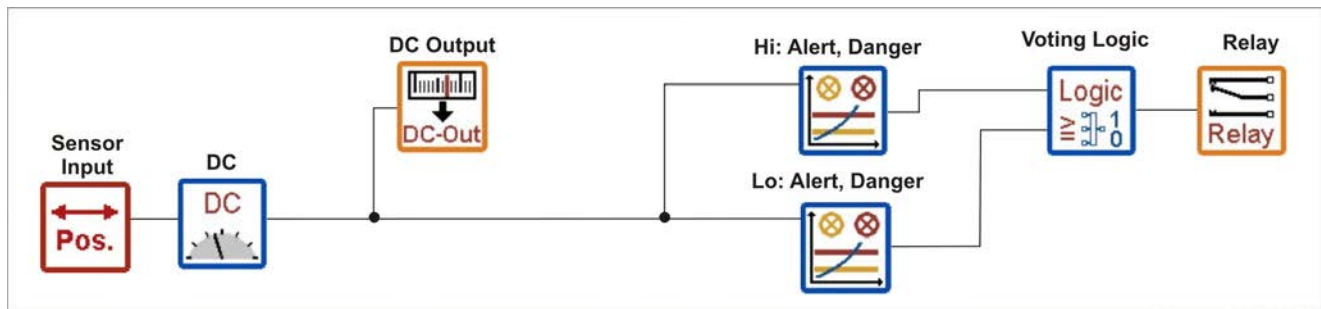

Figure 4. Axial displacement inputs (2 channels).

Technical Specifications

The specifications given below are specific for the SM-610-153 Monitoring Module. See the VC-6000 Product Specifications for features and functions common to all SM-610 Monitoring modules.

AC/DC Vibration Sensor Inputs

Input voltage range -21.5 to -1V

Input frequency range:

Accelerometer/velocity sensor 0.6Hz to 20kHz
 Displacement sensor DC to 20kHz

Input impedance:

Accelerometer >800kΩ
 Velocity sensor 50kΩ
 Displacement sensor >800kΩ

Gain:

Accelerometer:
 No integration 1 to 80 (±0.75%)
 Analogue integration 1 to 80 (±2.75%)
 Velocity sensor 1 to 80 (±0.75%)
 Displacement sensor 1 (±0.75%)

Sensitivity:

Accelerometer adjustable (typ. 100 or 10mV/g)
 Velocity sensor . adjustable (typically 100mV/mm/s)
 Displacement sensor adjustable (typ. 8mV/μm)

Common mode rejection:

DC to 30kHz typically 90dB
 30kHz to 100kHz typically 85dB

Maximum accelerometer input signal (100mV/g):

No integration 1.25 to 80g peak
 Analogue integration 12.5 to 150mm/s peak

Sensor power:

Sensor supply -24VDC ±2%
 Maximum current 30mA

Speed/Phase Reference Sensor Inputs

Input voltage range -21.5 to -1V
 Input frequency range DC to 20kHz
 Input impedance >800kΩ
 Gain 1 (±0.75%)

Common mode rejection:

DC to 10kHz typically 90dB
 10kHz to 100kHz typically 85dB

Sensor power:

Sensor supply -24VDC ±2%
 Maximum current 30mA

Buffered Outputs

Minimum output load 100kΩ
 Output gain 1 (±2%)
 Cross-talk typically -90dB (up to 50kHz)
 Inherent noise (1Hz to 50kHz) typically 10mV RMS
 Output impedance <100Ω
 Frequency range DC to 50kHz (phase shift <5%)
 Output offset ≤ ±13mV

Analogue DC Outputs

Current output:

Current range 4 to 20mA or 0 to 20mA
 Maximum output load 500Ω
 Accuracy <2.4% of measured value
 Offset <20μA

Voltage output:

Voltage range 0 to 10V or 2 to 10V
 Minimum output load 1kΩ
 Accuracy <1.3% of measured value
 Offset <9.5mV

Relay Outputs

Nominal working voltage 24V
 Maximum current 100mA

Measurements

Meas. Name	Frequency Range	Measuring Time	Detecti on	Alarm Limits	Measuring Range	Units ¹	Accuracy (25°C, 80Hz, 0-Peak)
Bandpass (ISO 10816)	HP: 1 to 10Hz (-1dB) LP: 1kHz (-1dB) 18dB/Octave (ISO 2954)	Adjustable 100ms to 100s in steps of 100ms	RMS, Peak, Peak-peak	1x Alert, 1x Danger	80g	g	±(0.08g + 0.75% of measured value)
					150mm/s (1 integration ²)	mm/s	±(0.6mm/s + 2.75% of measured value)
					100mm/s	mm/s	±(0.1mm/s + 0.75% of measured value)
Bandpass (ISO 7919)	HP: 1 to 10Hz (-1dB) LP: 1kHz (-1dB) 18dB/Octave (ISO 2954)	Adjustable 100ms to 100s in steps of 100ms	RMS, Peak, Peak-peak	1x Alert, 1x Danger	2000µm	µm	±(10.0µm + 1.0% of measured value)
S _{max}	HP: 1 to 10Hz (-1dB) LP: 1kHz (-1dB) 18dB/Octave (ISO 2954)	Adjustable 100ms to 100s in steps of 100ms	Peak	1x Alert, 1x Danger	2000µm	µm	±(10.0µm + 1.0% of measured value)
X-Y _{max}	HP: 1 to 10Hz (-1dB) LP: 1kHz (-1dB) 18dB/Octave (ISO 2954)	Adjustable 100ms to 100s in steps of 100ms	RMS, Peak, Peak-peak	1x Alert, 1x Danger	80g	g	±(0.08g + 0.75% of measured value)
					150mm/s (1 integration ³)	mm/s	±(0.6mm/s + 2.75% of measured value)
					100mm/s	mm/s	±(0.1mm/s + 0.75% of measured value)
					2000µm	µm	±(10.0µm + 1.0% of measured value)
DC (static shaft position)	-	Adjustable 10ms to 100s	-	2x Alert, 2x Danger	2mm	µm	±(2.0µm + 1.0% of measured value)
DC (axial)	-	Adjustable 10ms to 100s	-	2x Alert, 2x Danger	2000µm	µm	±(10.0µm + 1.0% of measured value)
Vector (1n, 2n, Jn, Kn, RMS overall and Residual value)	Fundamental: 0.33Hz-1kHz Bandwidth: 22%, 11%, 6%, 3% Upper freq.: 5kHz	Computed from bandwidth	RMS, Peak, Peak-peak	1x Alert, 1x Danger (1n)	Jn: 0.5n to 20n Kn: 4n to 20n	g, mm/s, µm ⁴	Magnitude: <1% + 0.2% of measured value
							Phase 10 to 200Hz: <2°
							Phase 5 to 500Hz: <4°
RPM	Signal slope: +/- Trigger level ⁵ (manual or automatic): -21.5 to -1V; adjustable in steps of 0.1V Hysteresis: 0 to 25; adjustable in steps of 0.1	Adjustable 10ms to 100s	RPM	1x Alert, 1x Danger	0.06 to > 1200000 RPM RPM multiplier and divider adjustable from 1 to 99999	RPM	Speed >10000rpm: ±0.01% of measured value Speed 100 to 10000 rpm: ±1 rpm Speed < 100 rpm: ±0.1 rpm (one pulse per revolution)

¹ Metric and imperial units can be used; Metric units are shown only as an example.

² One analogue integration is possible. An additional digital integration can be done but this will result in less accuracy.

³ One analogue integration is possible.

⁴ One analogue integration is possible. An additional digital integration can be done without loss of accuracy.

⁵ Please refer to the sensor input for the allowed input signal.

Brüel & Kjær Vibro reserves the right to change specifications without notice

Brüel & Kjær Vibro A/S
2850 Nærum – Denmark
Tel.: +45 7741 2500
Fax: +45 4580 2937
E-mail: info@bkvibro.com

Brüel & Kjær Vibro GmbH
64293 Darmstadt – Germany
Tel.: +49 (0) 6151 428 1100
Fax: +49 (0) 6151 428 1200
E-mail: info@bkvibro.de