

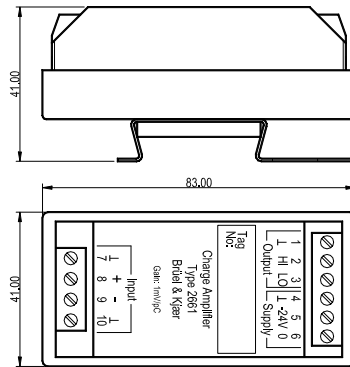

Charge Amplifier type 2661 data sheet

1. Application

Charge Amplifier.



2. Usage

Type 2661 is intended for connection to charge type accelerometers, when monitoring plant machinery in harsh environments, for industrial machine installations and for gas turbine applications requiring long mean time between failures.

The type 2661 has a differential input which improves the signal/noise ratio in strong electromagnetic fields when used together with balanced accelerometers, such as BK-Vibro Type 8315 and Type 8324.

If single-ended accelerometers are used the “-” input terminal of the preamplifier must be connected to the ground terminal.

To protect the Type 2661 from harsh environmental conditions, such as humidity and vibration, it should be mounted in a junction box in conformity with IP 65, as available from Brüel & Kjær Vibro.

Type 2661 is available in a number of versions when other amplification factors or filtering ranges are required.

3. Technical Data

Balanced Charge Input

Sensitivity: 1 mV/pC, $\pm 2\%$ - 80 Hz
 Frequency range: 1 Hz to 100 kHz ± 0.5 dB
 Max. Input Signal: 8 nC
 High-Pass Filter: 2nd order, -3 dB @ 0.48 Hz
 Common Mode Rejection: > 30 dB (1 Hz to 50 kHz)
 Noise : < 40 x 10⁻³ pC referred to input terminated with 1 - 4 nF,
 2 Hz to 50 kHz
 Source Impedance: > 50M Ω
 Effects of Source Impedance on Low Frequency Response:

10 M Ω \Rightarrow 2 dB peak @ 0.8 Hz
 4 M Ω \Rightarrow 5 dB peak @ 0.8 Hz
 2 M Ω \Rightarrow 8 dB peak @ 0.9 Hz

Connections: Screw terminals
 Max. wire gauge: 1.5 mm²

Output

Min. voltage deviation: -2 V to -18 V unloaded
 DC offset: - 10 V
 Output Impedance: 2 x 5 Ω
 Short Circuit Time: Infinite
 Drive Capacity: Min. 13 mA peak
 Connections: Screw terminals

Environmental*

Temperature:
 Operating temperature: -40° to +85°C (-40°F to +185°F)
 Non-Operating Temperature: -55°C to +100°C (-67°F to +212°F)
 Humidity: +30°C, 95% RH
 Electromagnetic Sensitivity: < 0.15 μV/A/m
 Enclosure: Protection class IP20

Power Supply

Voltage Supply: - 24 V ± 4 V
 Quiescent Current Consumption: < 7.4 mA (typically 5 mA)
 Incorrect installation:
 Connections to the output and supply terminals can be arbitrarily switched around without over-loading the preamplifier.

Note: All values are typical at 25°C (77°F, unless measurement uncertainty is specified. All uncertainty values are specified at 2σ (i.e. expanded uncertainty using a coverage factor of 2).

Physical

Height: 41 mm (1.614 in)
 Width: 41 mm (1.614 in)
 Length: 83 mm (3.268 in)
 Weight: 125 g (0.27 lb)

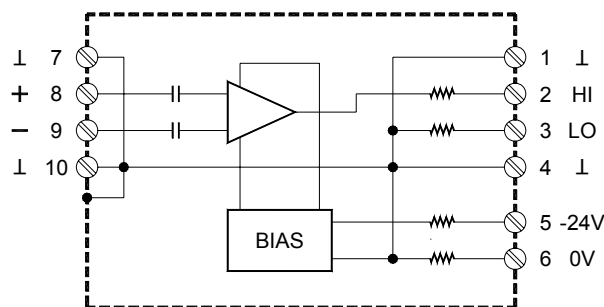

Electrical layout

* These specifications pertain only to the preamplifier/junction box set-up.

4. Connection

The preamplifier must be mounted in a shielded junction box on a DIN-rail.

Guidelines for connecting transducers to Charge Amplifier type 2661:

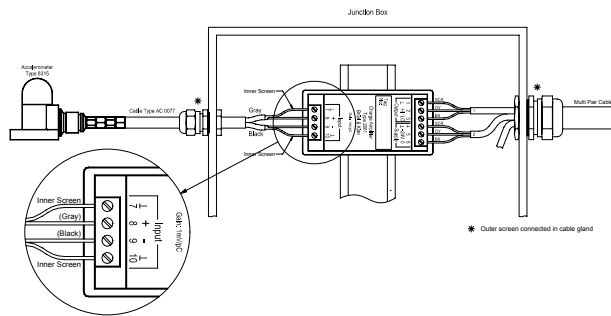

Connection to a differential accelerometer

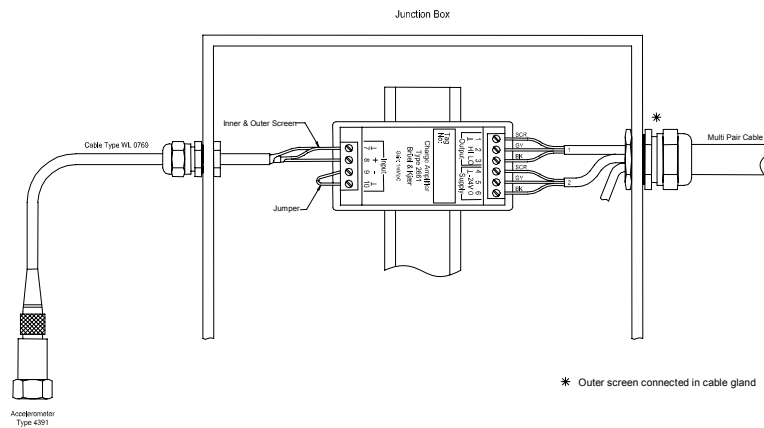

Connection to a single-end accelerometer.

Note: It may be advantageous to use Microdot Input Adaptor type EQ2353 for connection of single-end accelerometers.

The figure(s) shows the Type 2661 with connected cable(s).

5. Versions

Type 2661 may be delivered in several versions.

Standard version in **bold**.

Type number	Sensitivity	Filter	Power Supply
2661	1mV/pC	1Hz-100kHz	-24V
2661-S-0-001-104-S	1mV/pC	1Hz-100kHz	±12V
2661-S-0-025-053	1mV/pC	25Hz-5kHz	-24V
2661-S-004	10mV/pC	0.2Hz-100kHz	-24V
2661-S-005	1mV/pC	0.5Hz-100kHz	-24V
2661-S-1-001-104-P	10mV/pC	1Hz-100kHz	+24V
2661-S-1-025-053	10mV/pC	25Hz-5kHz	-24V
2661-S-3-001-104-P	25mV/pC	1Hz-100kHz	+24V
2661-S-4-001-104-P	3mV/pC	1Hz-100kHz	+24V
2661-S-5-001-104-P	5mV/pC	1Hz-100kHz	+24V
2661-S-6-010-053-N	55.8mV/pC	10Hz-5kHz	-24V
2661-S-7-002-503-N	44.25mV/pC	10Hz-5kHz	-24V
2661-WH2824	0,1 mV/pC	1Hz-100kHz	-24V
2661-WH2825	10 mV/pC	1Hz-100kHz	-24V
2661-WH3132	1mV/pC	10Hz-5kHz	-24V
2661-WH3133	10mV/pC	10Hz-5kHz	-24V

Brüel & Kjær Vibro A/S reserves the right to change specifications without notice