

## Optical Reference Sensor P - 84

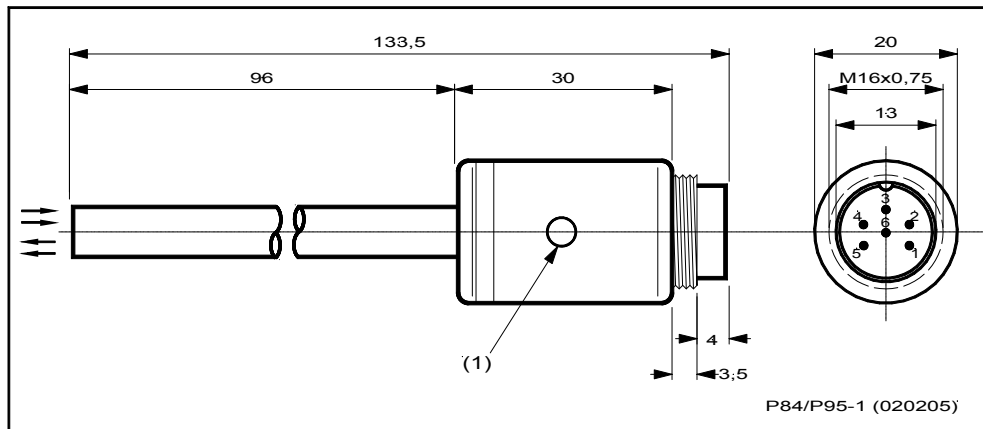

Fig. 1 Reference sensor P-84

### 1 Application

The reference sensor P-84 is used predominantly for **speed measurement** and for establishing an **angular reference** with a rotating machine component.

With the help of the connecting cable AC-185, it is linked directly with the vibration measuring instrument, e.g. VIBROPORT 41.

### 2 Working Principle

The P-84 operates according to the photoelectrical principle. It transmits a light beam to the machine part undergoing investigation. The light transmitted by the sensor is reflected by a **reference mark** applied to the machine component (see below). A phototransistor at the tip of the reference sensor is triggered by the reflected light, causing a change in the output signal.

### 3 Technical Data

Working distance **30 ... 40 mm;**  
with reflective tape SCOTCHLITE HIGH GAIN  
RP 7610 **up to 100 mm**

Power supply cf. Figure.2

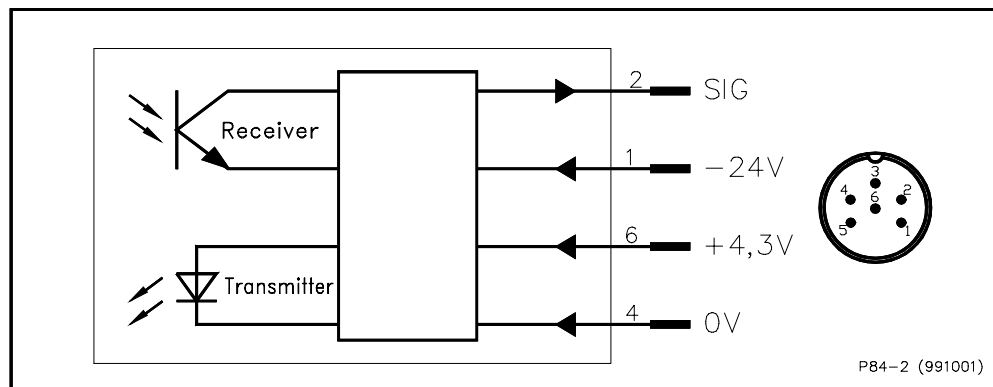

Fig. 2 Connection of P-84 pickup

1 Max. output level with vertical installation optimum scanning distance and highly reflective light mark (shiny shaft, reflecting foil)	approx. 16.5 V
Min. output level with non-reflecting black mark without parasitic scattered light (in practical operation the min. value is -0.2 V)	approx. 0 V
Input resistance $R_E$ of connected measuring instrument	$\geq 10 \text{ k}\Omega$
Length of connecting cable	$\leq 100 \text{ m}$
Working temperature	$0 \text{ }^\circ\text{C} \dots + 50 \text{ }^\circ\text{C}$
Storage temperature	$-30 \text{ }^\circ\text{C} \dots + 100 \text{ }^\circ\text{C}$
Protective rating	IP 30
Weight	approx. 70 g (excluding connection cable)

## 4 Reference Mark

The reference mark, also called "Black-and-white mark", is applied to a suitable point on the shaft surface. Its reflection can be clearly distinguished from the surrounding surface. It might either be absorbing or reflecting. The colour is of no importance. The mark might be attached to the circumference or to the front face of the shaft.

The **absorbent part** of the mark can consist, e.g., in:

- ◆ matt black paint finish
- ◆ matt black adhesive tape
- ◆ sand-blast surface

The **reflective part** can consist, e.g. in:

- ◆ the shiny shaft itself
- ◆ a coat of aluminium bronze
- ◆ reflective tape

***The mark needs to be at least 5 mm long !***

## 5 Assembly and Adjustment

- ◆ To fasten the reference pickup, we recommend using a magnetic stand.
- ◆ Normally the reference sensor needs to be installed perpendicular to the surface to be scanned, so that a sufficient quantity of the reflected light is received by the sensor. This is not necessary, if the reflective tape mentioned above is used. It reflects the light in all directions and thus enables the sensor to be installed at an angle (see section 6).
- ◆ The tip of the scanning head should be at a distance between 30 and 40 mm from the reference mark.
- ◆ The curve of the output signal depends on the width and the amount of reflection of the reference mark and its distance to the reference sensor (see Fig. 3).

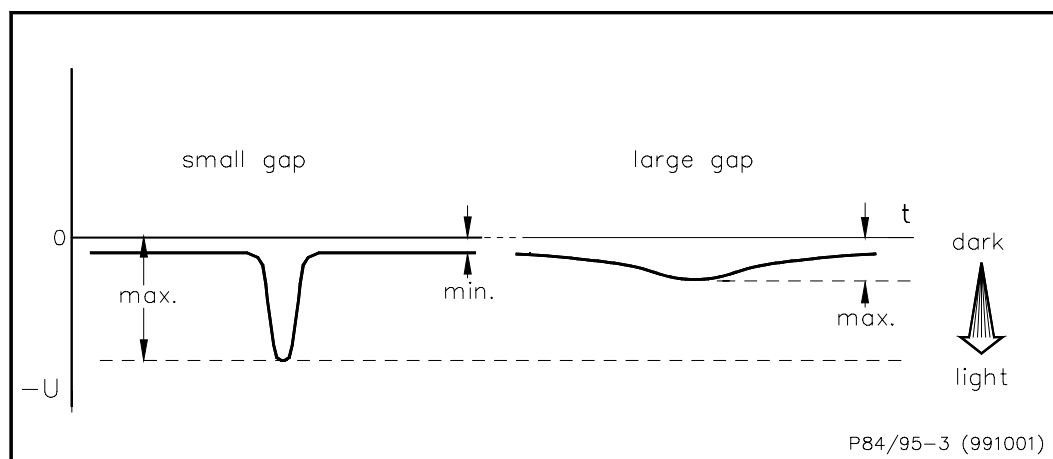

Fig. 3 Output signal as a function of distance

## 6 Problems during reference generation?

If no satisfactory result can be achieved inspite of correct connection of the reference sensor and appropriate setting of the used measuring unit, the output signal of the reference sensor might not permit a clear distinction between the reference mark and its environment. The follow-up electronics are not able to trigger correctly.

Fig. 4a) to d) show and describe the most frequent causes of this problem. Fig. 4a) shows an ideal output signal.

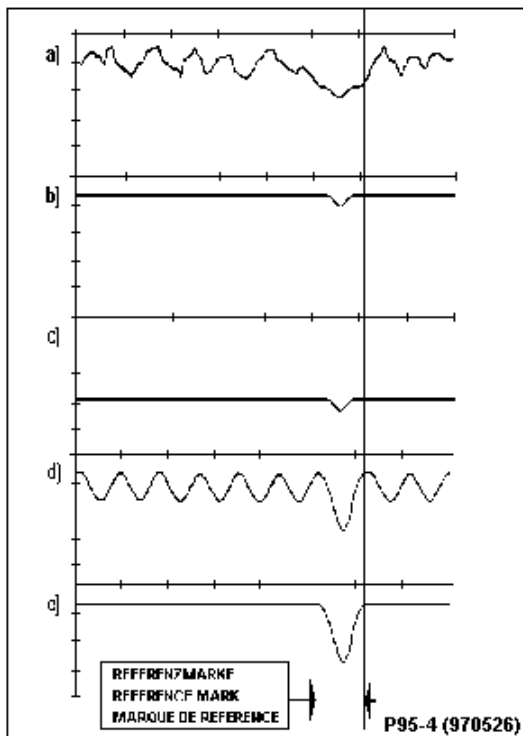

Fig. 4 Output signals of the reference sensor with different conditions.

**a)** Strong "noise" of the shaft surface (uneven reflection due to grooves or different surface structure) and the relatively low voltage rise in the area of the reference mark cause **multiple triggering**.

**b)** If the distance is **too big**, the amount of absorbed light is insufficient. This causes insufficient rise of the output voltage and thus **loss of reference**.

**c)** If the distance is **too small** (saturation of the receiving diode) or when daylight scatters in, the voltage rise of the output signal might be drastically reduced and thus **reference will be lost** as mentioned under b).

**d)** Parasitic scattered light from a.c. light sources might cause **multiple triggering**.

**e)** With correct conditions the signal level in the area of the reference mark can be clearly distinguished from that of the surrounding area and thus supplies a **stable reference**.

## Recommendations and measures:

The problems described above can safely be avoided by using reflecting foil SCOTCHLITE GAIN RP 7610 (Manufacturer: 3M). This foil has the following decisive characteristics:

◆ **Factor 1000 of Reflection compared with white colour.**

The foil can thus be used as a white mark even on highly shiny shaft surfaces.

◆ **Reflection of light in all directions.**

This characteristic enables inclined installation of the reference sensor. This helps absorption of a big amount of transmitted light whereas undesired reflections are received by the shaft either weakly or even not at all.

The characteristics of the reflecting foil result in the following recommendations:

- ◆ The optimum distance of the scanning head of the reference sensor to the shaft should be **30 ... 40 mm**. The receiving diode might reach saturation if the distance is 20 mm.
- ◆ The optimum angle of the reference sensor vertical to the axis of shaft rotation should be **0 ... 15°** (see Fig 5). Vertical installation might lead to undesired reflection, the signal rise will be too low at angles above 30°.
- ◆ Measuring instruments such as VIBROPORT 41 as well as all other units of "Series 40" enable setting of a trigger level of 10 %, 50 % and 90 % of the reference signal. Only settings **50 % and 90 %** are recommended when using reflecting foil.

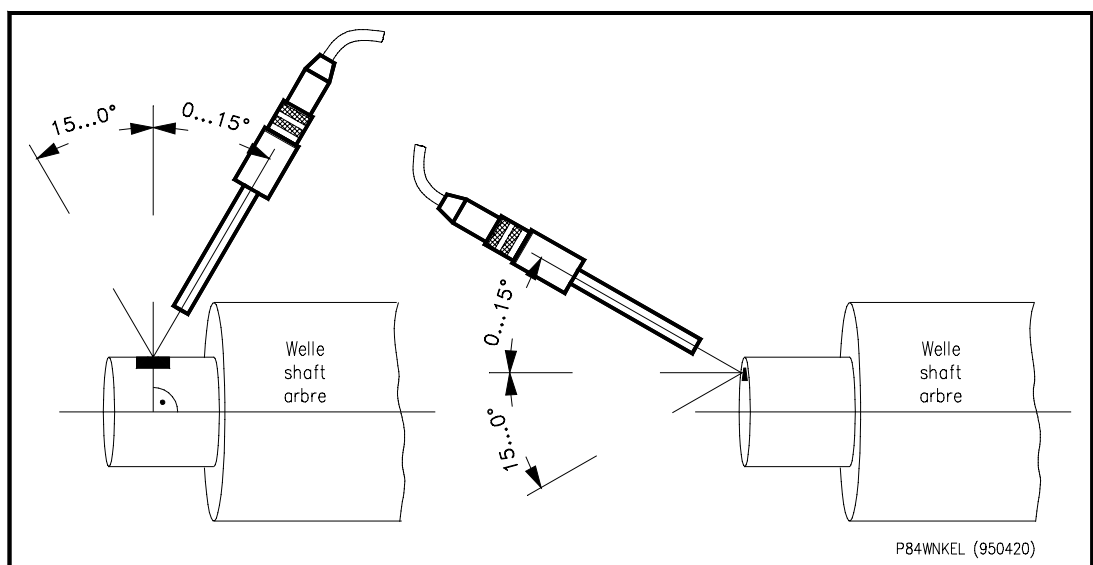

Fig. 5 Optimum installation angle of the reference sensor

## Help through signal monitoring by oscilloscope

In case of doubt, record the reference signal by using an oscilloscope or through measuring task "Oscilloscope" on a Series 40 unit and assess the progress of the signal.